

# 20 PARK CRESCENT

SG DIAGRAM

SIDES metres		DIRECTIONS	Y	CO-ORDINATES WG. 31 (Approx.)		X	S . G . No.
		Constants	+	0.00	+3 290 000.00		538/2008
AB	79.39	341.16.00	A	+ 16 641.13	+ 3 259.20		Approved
BC	116.42	79.06.10	B	+ 16 615.63	+ 3 334.38		<i>[Signature]</i>
CD	7.54	194.08.30	C	+ 16 729.95	+ 3 356.39		Surveyor-General
DE	50.02	180.05.30	D	+ 16 728.11	+ 3 349.09		2008-03-27
EA	95.61	245.21.20	E	+ 16 728.03	+ 3 299.07		ORD 27 OF 1949
EF	2.20	0.05.40					2007/1081
FG	40.68	65.21.20	F	+ 16 728.03	+ 3 301.27		
GH	10.65	37.21.30	G	+ 16 765.01	+ 3 318.24		
HJ	23.69	65.21.20	H	+ 16 771.48	+ 3 326.70		
JK	7.70	179.58.20	J	+ 16 793.00	+ 3 336.58		
KE	71.49	245.21.20	K	+ 16 793.01	+ 3 328.88		

The figure 1. A B C D E represents a Conservation Servitude  
 2. E F G H J K represents a Services Servitude

both over ERF 497 FOREST HILLS

situate in the eThekweni Municipality : Outer West Operational Entity,  
 Registration Division FT, Province of KwaZulu - Natal

Surveyed in October 2007 and January 2008  
 by me

*[Signature]*  
 Professional Land Surveyor

(A.F. van Jaarsveld - Registration No. PLS 1125)

This diagram is annexed to  No.  <div style="text-align: right;">Registrar of Deeds</div>	The original diagram is S.G. No. 474/1959  Deed of Transfer No. 10820/1969	File No. /2 Vol 2  S.R. No. 171/2008  Comp. FT-8B-2B
---	--	--

ERF 497 FOREST HILLS

S . G . No.  
538/2008

Approved

*D. H. Stal*

Surveyor-General  
2008-03-27

ORD 27 OF 1949  
2007/1081

DESCRIPTION OF BEACONS

- A : 12mm iron peg near wooden fence post
- B, C, D, E, F, G, H, J : 12mm iron pegs
- K : 25mm iron pipe in concrete

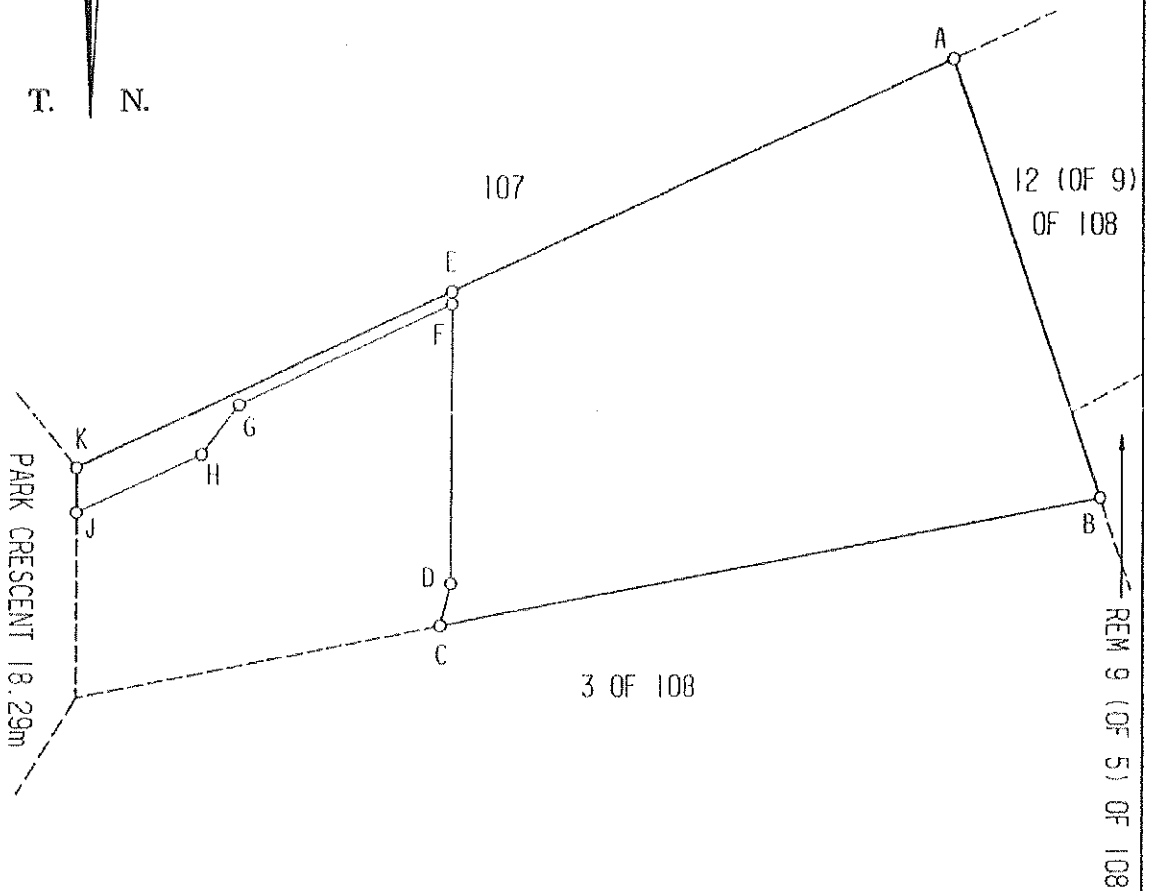
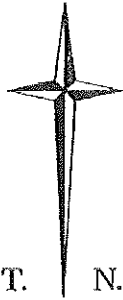

SCALE 1:1250

Surveyed in October 2007 and January 2008  
by me

*A. F. van Jaarsveld*

Professional Land Surveyor

(A.F. van Jaarsveld - Registration No. PLS 1125)

SIDES metres		DIRECTIONS		CO-ORDINATES WG. 31 (Approx.)		S. G. No.
				Y	X	
		Constants		+	0.00	+3 290 000.00
AB	10.87	326.31.50	A	+	16 784.20	+ 3 332.54
BC	30.97	276.33.10	B	+	16 778.21	+ 3 341.61
CD	20.79	302.44.50	C	+	16 747.44	+ 3 345.15
DE	64.19	79.06.10	D	+	16 729.95	+ 3 356.39
EF	31.95	179.58.20	E	+	16 792.99	+ 3 368.53
FA	9.68	245.21.20	F	+	16 793.00	+ 3 336.58

539/2008  
Approved  
*[Signature]*  
Surveyor-General  
2008-03-27

ORD 27 OF 1949  
2007/1081

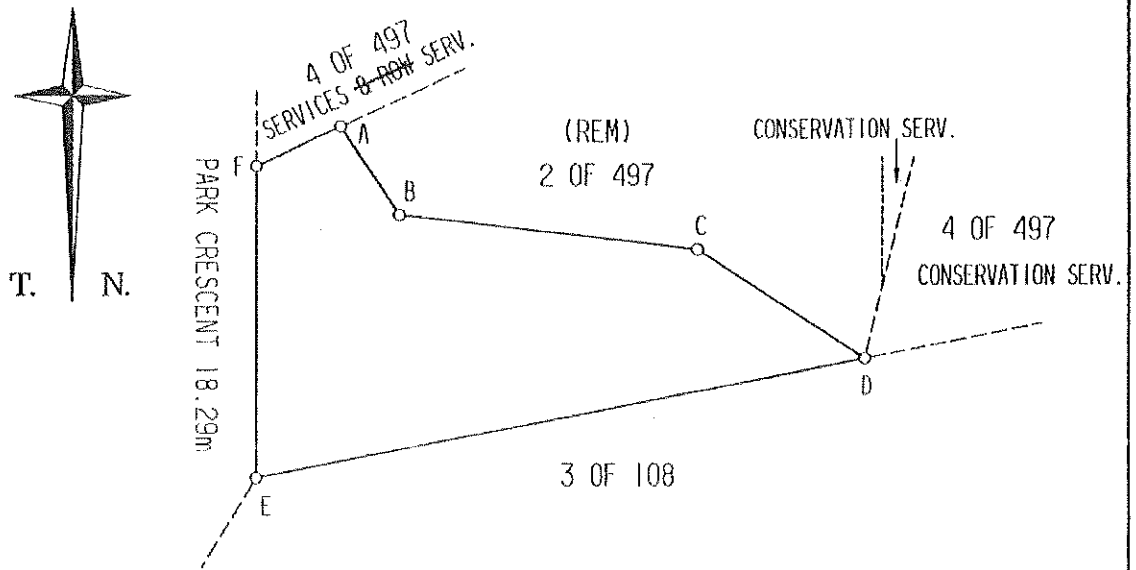

DESCRIPTION OF BEACONS

A, B, C, D, F : 12mm iron pegs  
E : 12mm drill hole in concrete near corner brick pillar

The figure A B C D E F

represents **1189 Square Metres** of land, being  
**PORTION 1 OF ERF 497 FOREST HILLS**

situate in the eThekweni Municipality, Outer West Operational Entity  
Registration Division FT, Province of KwaZulu-Natal

Surveyed in October 2007 and January 2008  
by me

*[Signature]*  
Professional Land Surveyor

(A.F. van Jaarsveld - Registration No. PLS 1125)

This diagram is annexed to  No.	The original diagram is S.G. No. 474/1959	File No. /2 Vol 2
	Deed of Transfer No. 18820/1969	S.R. No. 171/2008
Registrar of Deeds		Comp. FT-BB-28

SIDES metres	DIRECTIONS	CO-ORDINATES WG. 31 (Approx.)			S . G . No.	
		Y	X			
		Constants	+	0.00	+3 290 000.00	540/2008 Approved  Surveyor-General 2008-03-27 ORD 27 OF 1949 2007/1081
AB	21.68	289.31.50	A	+ 16 768.69	+ 3 323.05	
BC	24.67	272.02.20	B	+ 16 748.26	+ 3 330.30	
CD	26.00	14.08.30	C	+ 16 723.60	+ 3 331.18	
DE	20.79	122.44.50	D	+ 16 729.95	+ 3 356.39	
EF	30.97	96.33.10	E	+ 16 747.44	+ 3 345.15	
FG	10.87	146.31.50	F	+ 16 778.21	+ 3 341.61	
GH	14.00	245.21.20	G	+ 16 784.20	+ 3 332.54	
HA	4.59	217.21.30	H	+ 16 771.48	+ 3 326.70	

SERVITUDE NOTE

The figure JCK represents a Conservation Servitude.  
 Vide Diagram S.G. No. 538/2008 and

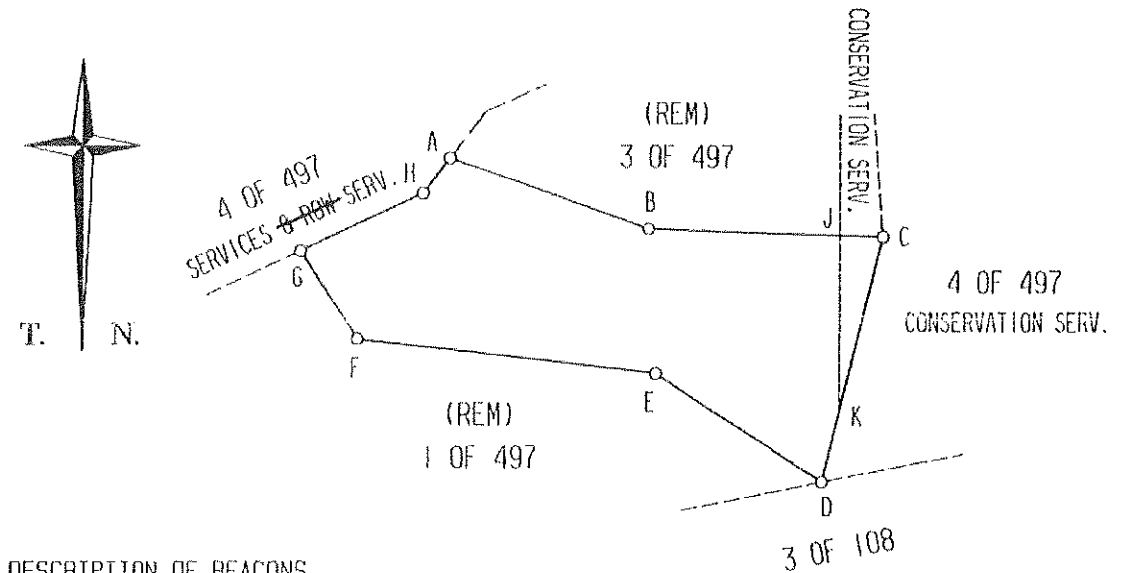

DESCRIPTION OF BEACONS

A, B, C, D, E, F, G, H : 12mm iron pegs

The figure A B C D E F G H

SCALE 1:750

represents 974 Square Metres of land, being  
PORTION 2 OF ERF 497 FOREST HILLS

situate in the eThekweni Municipality, Outer West Operational Entity  
 Registration Division FT, Province of KwaZulu-Natal

Surveyed in October 2007 and January 2008  
 by me

  
 Professional Land Surveyor

(A.F. van Jaarsveld - Registration No. PLS 1125)

This diagram is annexed to  No.	The original diagram is S.G. No. 474/1959	File No. /2 Vol 2
	Deed of Transfer No. 18820/1969	S.R. No. 171/2008
Registrar of Deeds		Comp. FT-88-28



SIDES metres		DIRECTIONS	Y	CO-ORDINATES WG. 31 (Approx.)		X	S . G . No.
		Constants	+	0.00	+3 290 000.00		542/2008
AB	79.39	341.16.00	A	+ 16 641.13	+ 3 259.20		Approved
BC	116.42	79.06.10	B	+ 16 615.63	+ 3 334.38		<i>[Signature]</i>
CD	26.00	194.08.30	C	+ 16 729.95	+ 3 356.39		Surveyor-General
DE	31.00	175.51.50	D	+ 16 723.60	+ 3 331.18		2008-03-27
EF	43.11	65.21.20	E	+ 16 725.83	+ 3 300.26		ORD 27 OF 1949
FG	10.65	37.21.30	F	+ 16 765.01	+ 3 318.24		2007/1081
GH	23.69	65.21.20	G	+ 16 771.48	+ 3 326.70		
HJ	7.70	179.58.20	H	+ 16 793.00	+ 3 336.58		
JA	167.10	245.21.20	J	+ 16 793.01	+ 3 328.88		

SERVITUDE NOTES

1. The figure ABCDEKL represents a Conservation Servitude.  
Vide Diagram S.G. No. 538/2008 and
2. The figure LKFGHJ represents a Services ~~and Right of Way~~ Servitude.  
Vide Diagram S.G. No. 538/2008 and

The figure A B C D E F G H J  
represents 7122 Square Metres of land, being  
PORTION 4 OF ERF 497 FOREST HILLS

situate in the eThekwin Municipality, Outer West Operational Entity  
Registration Division FT, Province of KwaZulu-Natal

Surveyed in October 2007 and January 2008  
by me

*[Signature]*  
Professional Land Surveyor

(A.F. van Jaarsveld - Registration No. PLS 1125)

This diagram is annexed to	The original diagram is	File No. /2 Vol 2
No.	S.G. No. 474/1959	S.A. No. 171/2008
Registrar of Deeds	Deed of Transfer No. 18820/1969	Comp. FT-8B-2B

PORTION 4 OF ERF 497 FOREST HILLS

DESCRIPTION OF BEACONS

- A : 12mm iron peg near wooden fence post
- B, C, D, E, F, G, H : 12mm iron pegs
- J : 25mm iron pipe in concrete

S . G . No.

542/2008

Approved

*Butcher*

Surveyor-General

2008-03-27

ORD 27 OF 1949

2007/1081

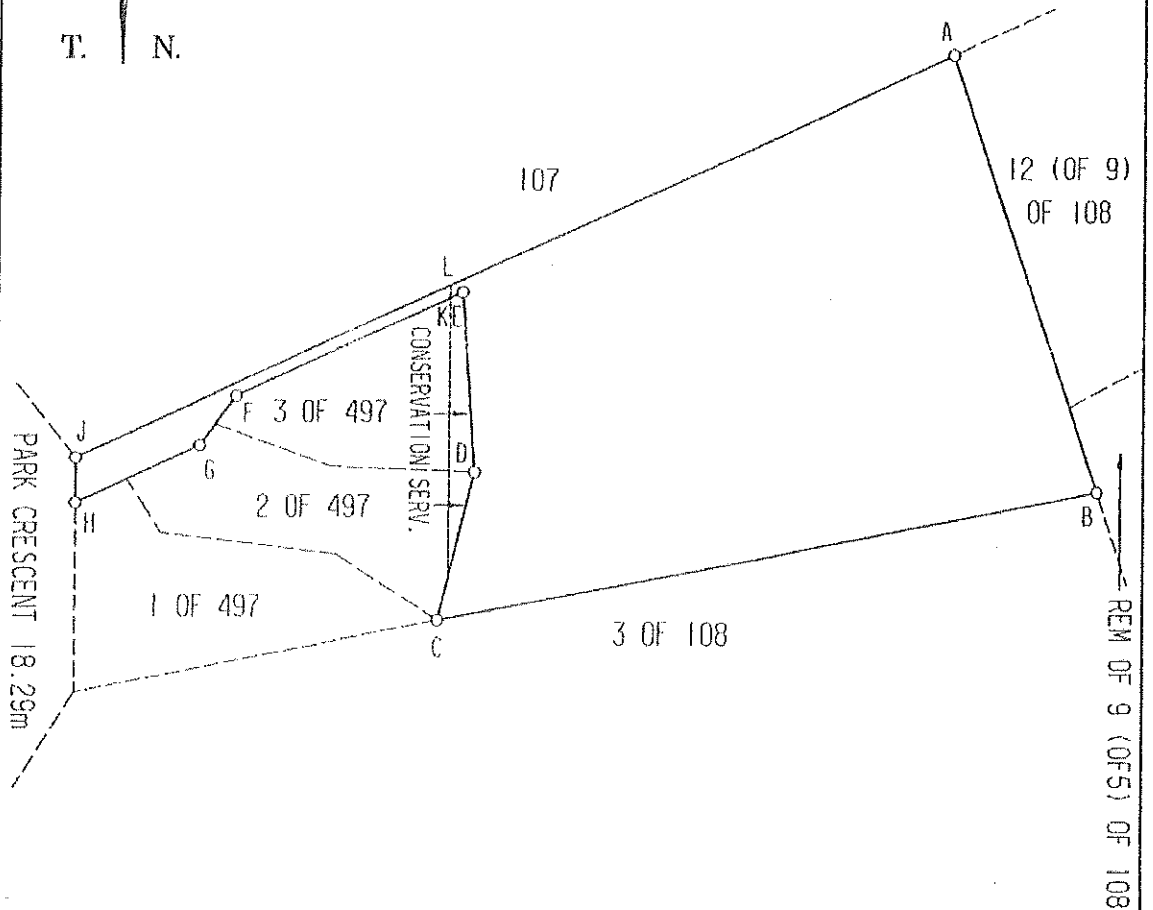

SCALE 1:1250

Surveyed in October 2007 and January 2008

by me

*A.F. van Jaarsveld*

Professional Land Surveyor

(A.F. van Jaarsveld - Registration No. PLS 1125)